

General information

Hybalans+ Manifold upper part right-angled 450

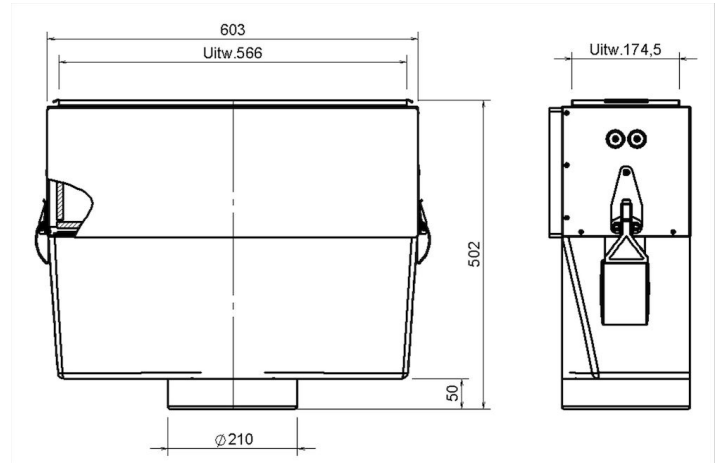
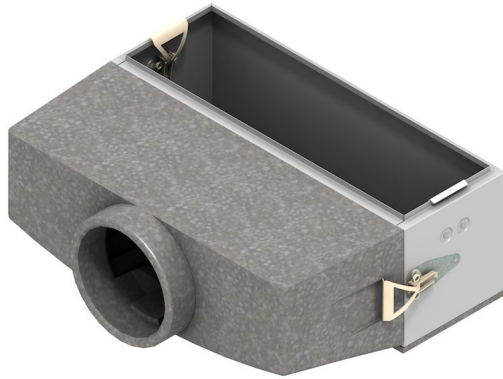

Specifications

Article number	400470442
Product category	Air extraction plenum / Air distribution
Material	Galvanized/EPP
Colour	RAL-7045
Wall Thickness (mm)	1
Weight (kg)	3,8

Dimensions

Dimensions (l x w x h mm)	603 x 230 x 502
Connection diameter flexible (mm)	-
Connection diameter rigid (mm)	150/180

Application Insights

Intended use	Air
Supply / Extract	Supply/Extract
Number of connections	-
Temperature range (°C)	-25 / +80

Technical Specifications

Maximum air flow (m ³ /h)	450
Air Tightness Class	3
R-value (m ² K/W)	0
Other specifications	-

Manifoldbox right-angled with flexible duct 92mm and insulated ducting 150mm

Pressure loss

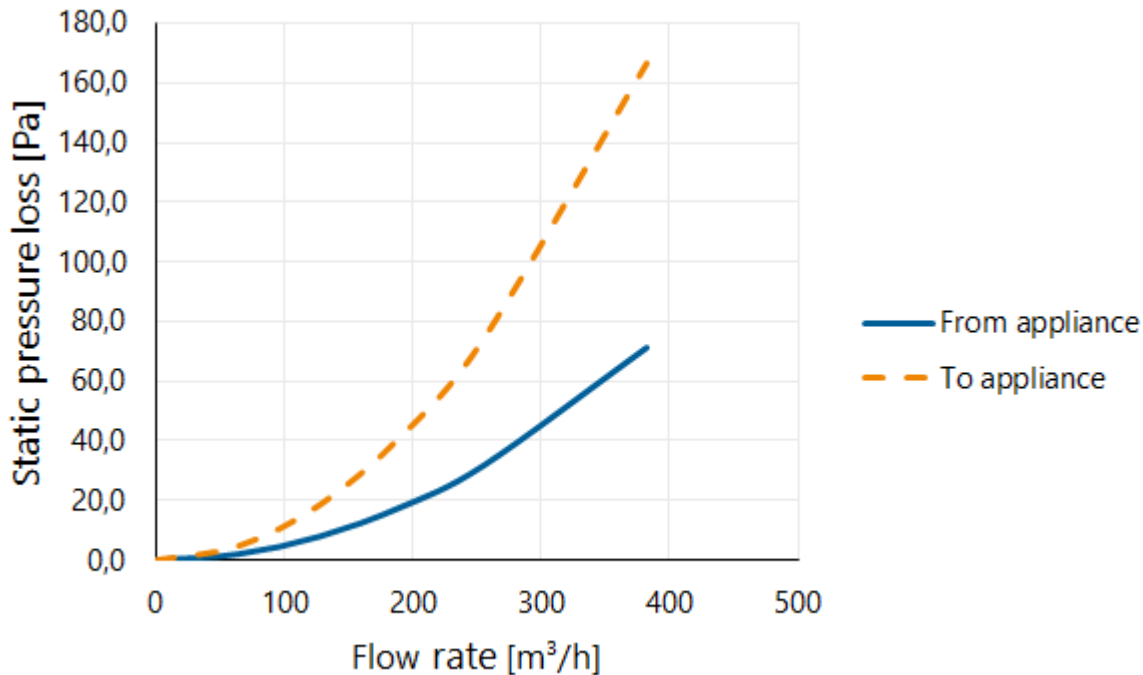

Manifoldbox right-angled with flexible duct 92mm and insulated ducting 150mm

Flow velocity pressure table

Flow rate			Static pressure loss	
[m/s]	[m³/h]	[l/s]	From appliance [Pa]	To appliance [Pa]
0	0	0	0,0	0,0
1	64	18	2,0	4,6
2	127	35	7,9	18,5
3	191	53	17,8	41,6
4	254	71	31,6	73,9
6	382	106	71,1	166,3