

General information

TwinSafe+ Elbow AL Concentric 60/100 90°

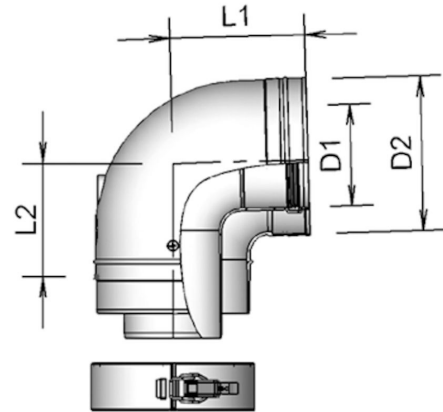

Specifications

Article number	400456222
Material flue duct	Aluminium
Quality class flue duct	EN 573-3: 2019; EN AW AlSi12(A)
Wall thickness flue duct nom (mm)	1,5
Material seal flue duct	Silicone Blue
Material air duct	Aluminum (coated)
Quality class air duct	EN 573-3: 2019; EN AW AlSi12(A)
Wall Thickness (mm)	0,4
Material seal air duct	EPDM
Colour air duct	White (RAL 9016)
Weight (kg)	0,71

Dimensions

Diameter flue duct nom (mm)	60
Diameter air duct nom (mm)	100
Outer dimensions (l x w x h mm)	185 x 152 x 110

Application Insights

Intended use	Exhaust of flue gases and supply of combustion air
Location class	For outdoor and indoor installation

Technical Specifications

Declaration of performance	001-MG-ALU DoP
Harmonized standard	EN 1856-1: 2009
System according to DoP	0,4
CE Marking	T200 P1 W V1 L10/11/13 150 000
ζF Flue duct	0,91
ζA Air duct	1,31
Thermal resistance flue duct (m ² K/W)	0
Thermal resistance air duct (m ² K /W)	0
Roughness value flue duct (m)	N.a.
Roughness value air duct (m)	N.a.
Equivalent length (m)	1,75
Other specifications	-

Mounting and installation

Always install according to the national regulations. For safe installation, consult the installation and associated mounting instructions, see Burgerhout.com.

Graph

Pressure loss versus flow rate

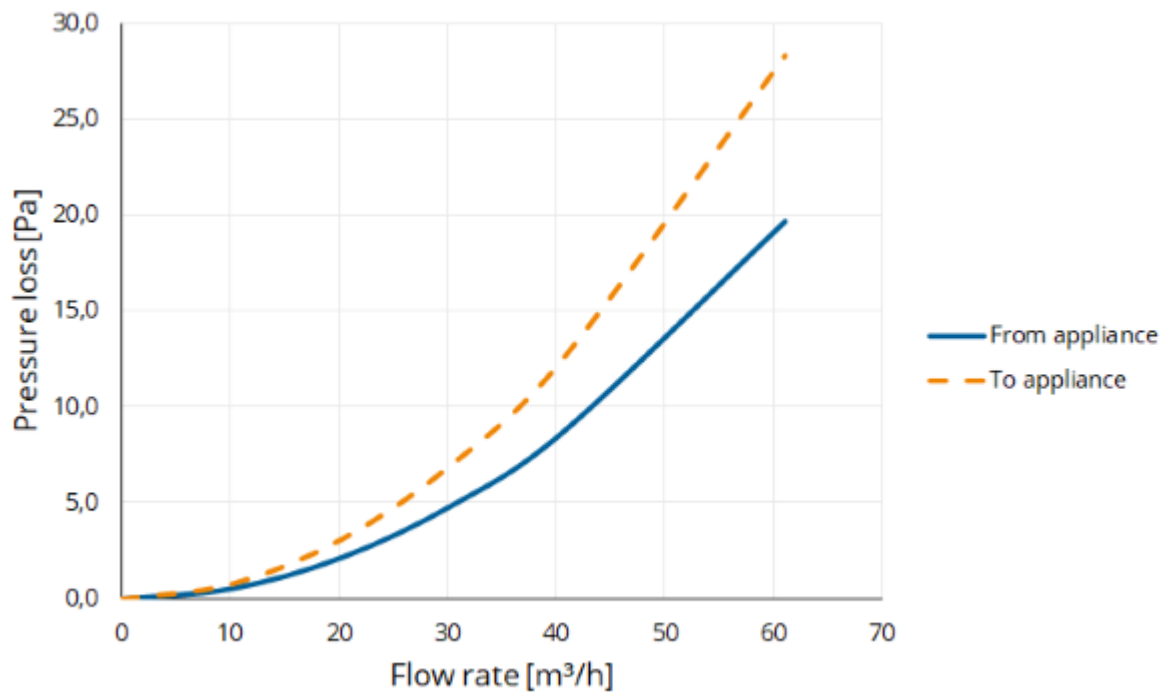

Table

Flow rate versus pressure loss

Flow rate			Static pressure loss	
[m/s]	[m³/h]	[l/s]	From appliance [Pa]	To appliance [Pa]
0	0	0	0,0	0,0
1	10	3	0,5	0,8
2	20	6	2,2	3,1
3	31	8	4,9	7,1
4	41	11	8,7	12,6
6	61	17	19,7	28,3